

Overview of short-wavelength FEL facilities

*Workshop Opportunités Scientifiques d'une source de 4ème
génération d'énergie intermédiaire, en France*

Oct 23/24, 2008, Université Pierre et Marie Curie, Paris

Thomas Tschentscher
thomas.tschentscher@xfel.eu



The European
X-Ray Free-Electron Laser Project

XFEL

Outline

Results of current research

- soft x-ray FEL research
- hard x-ray preparatory work

Technology choices

- SASE process
- seeding schemes

Overview & status of facilities

- world-wide
- in Europe

Aspects of FELs for user operation

- general
- FLASH experience

Outlook/Summary

Challenges for x-ray research

Coherent X-ray scattering

- structure of large, complex molecules and nanoscale systems
- dynamics in disordered and soft-matter systems

Time-resolved investigation of ultrafast processes

- transient; short-lived states; ultrafast phase transitions
- disentanglement of excitation and relaxation processes

Optical/Non-linear phenomena

- high intensity processes in atoms, solids, plasmas
- laser-like control of x-ray beams

Extremely small cross-section processes

- Ultra-dilute sample systems
- Processes of higher order

! X-ray pulse duration - Pulse intensity - Coherence !

Photoelectric effect at ultrahigh intensities

A.A. Sorokin et al., PRL 99, 213002(07)

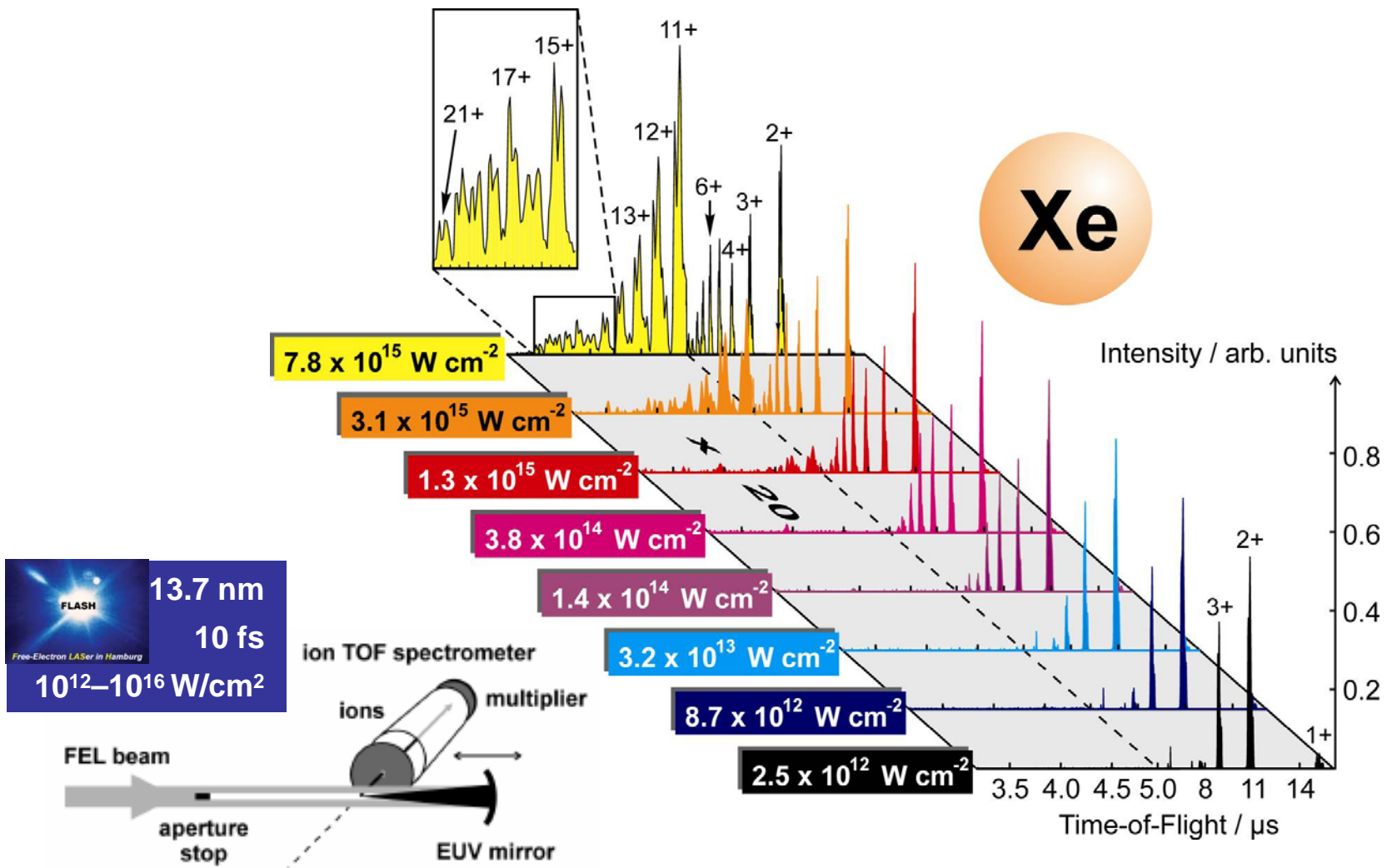

Atomic and molecular sciences

Photo-dissociation of molecular ions

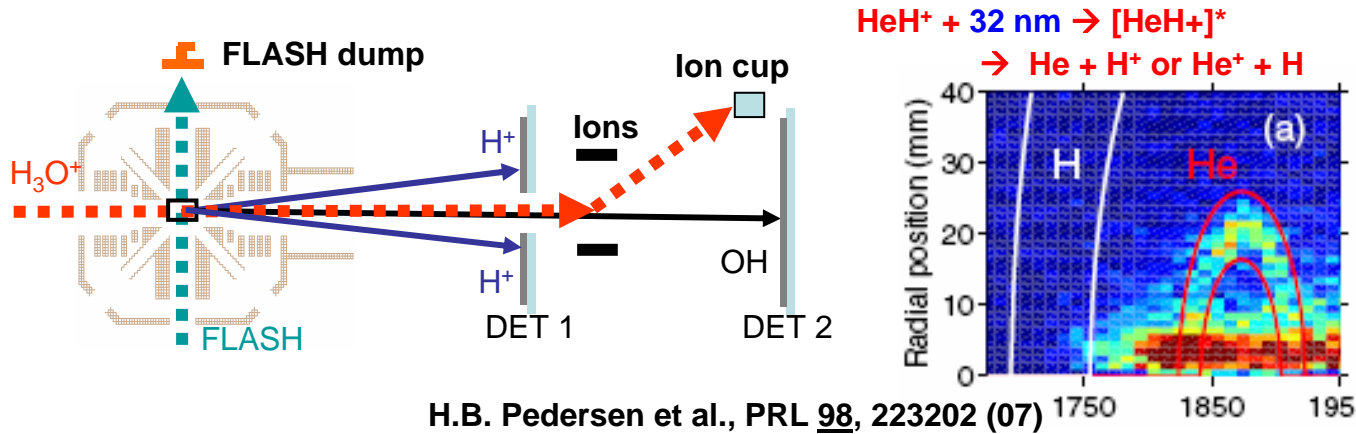

Recent work:

- added 2nd detector for light ions
- $H_3O^+ + 13.5 \text{ nm} \rightarrow H_3O^{2+} \rightarrow OH + 2H^+ \text{ or } H_2O^+ + H^+$

Transitions of highly excited ions

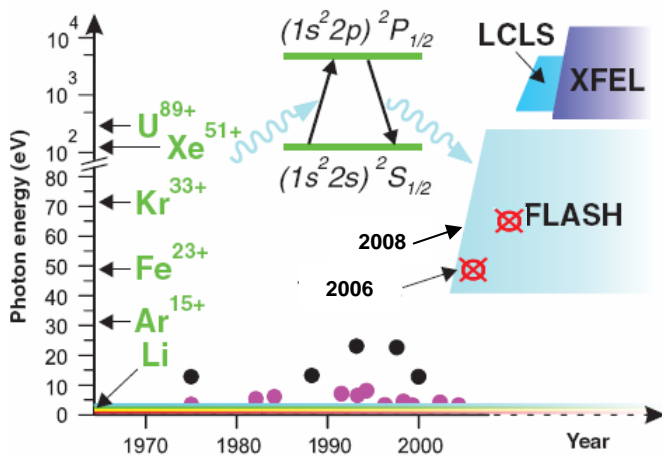

S.W. Epp et al., PRL 98, 183001 (2007)

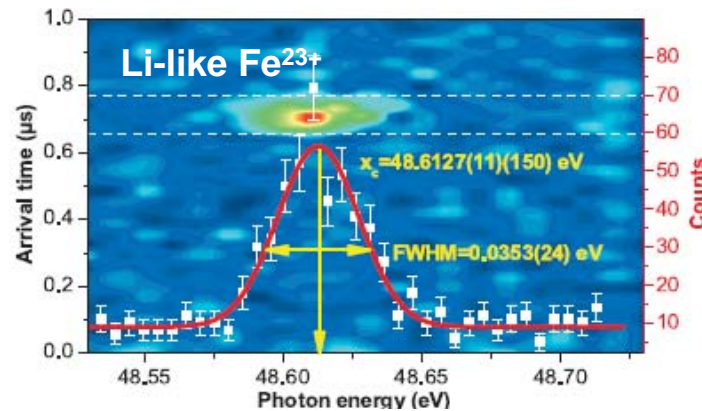

Recent work:

- improved accuracy 25 ppm \rightarrow 8 ppm
- calibration absolute acc. 8 ppm
- $Fe^{23+} 2s_{1/2} - 2p_{1/2, 3/2}$ at 49 and 65 eV

X-ray induced condensed-matter excitations

Transient reflectivity change

- GaAs
- 800 & 400 nm opt.

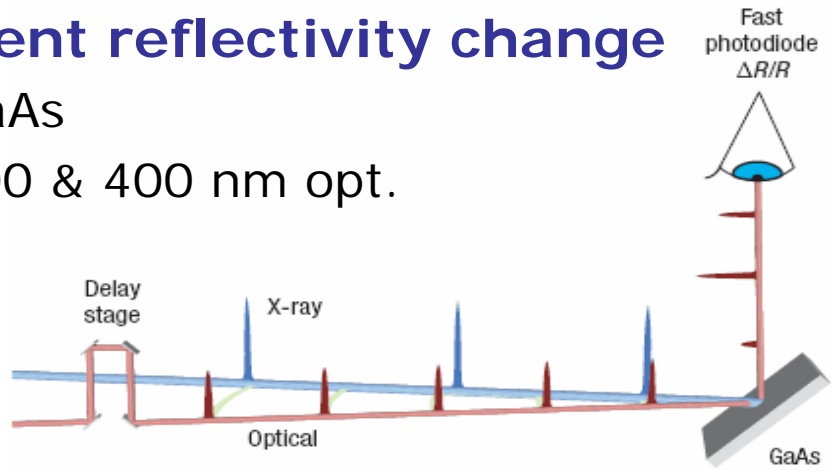

C. Gahl et al., Nature Photonics 2, 165 (2008)

FLASH
Free-Electron LASer in Hamburg
30 nm
< 50 fs
few 10¹¹ W/cm²

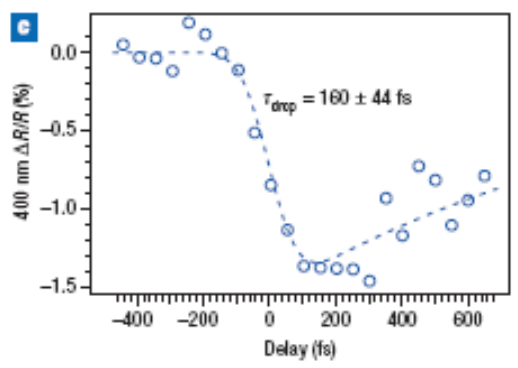
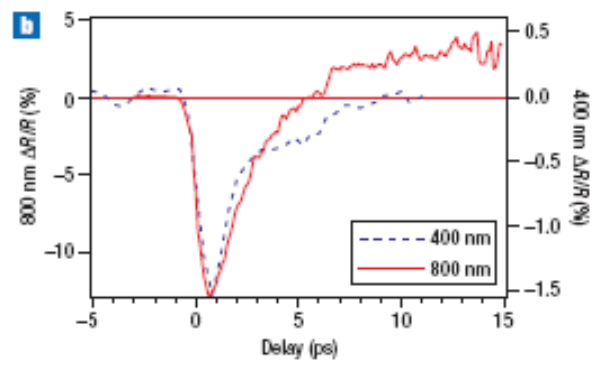
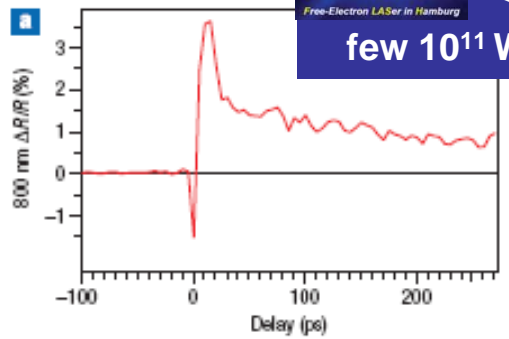

Spatially dispersed measurement

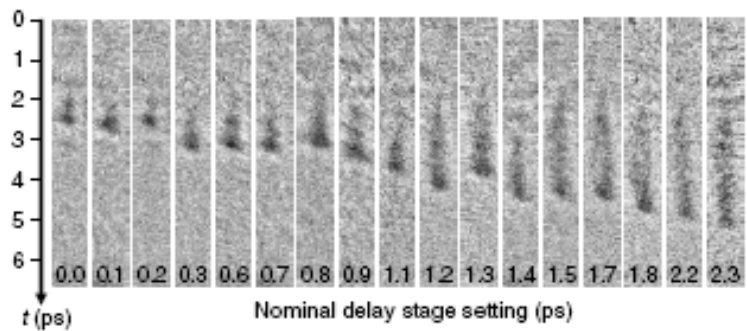

FLASH
Free-Electron LASer in Hamburg
28 nm
20-30 fs
< 10¹¹ W/cm²

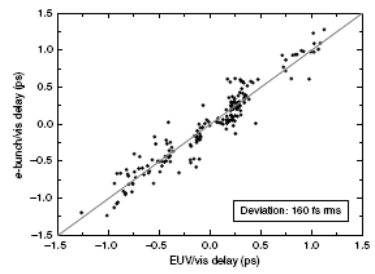

Th. Maltezopoulos et al., NJP 10, 033026 (2008)

Experiments at FLASH

Particle explosion at fs timescales

Femtosecond time-delay x-ray holography

- polystyrene balls

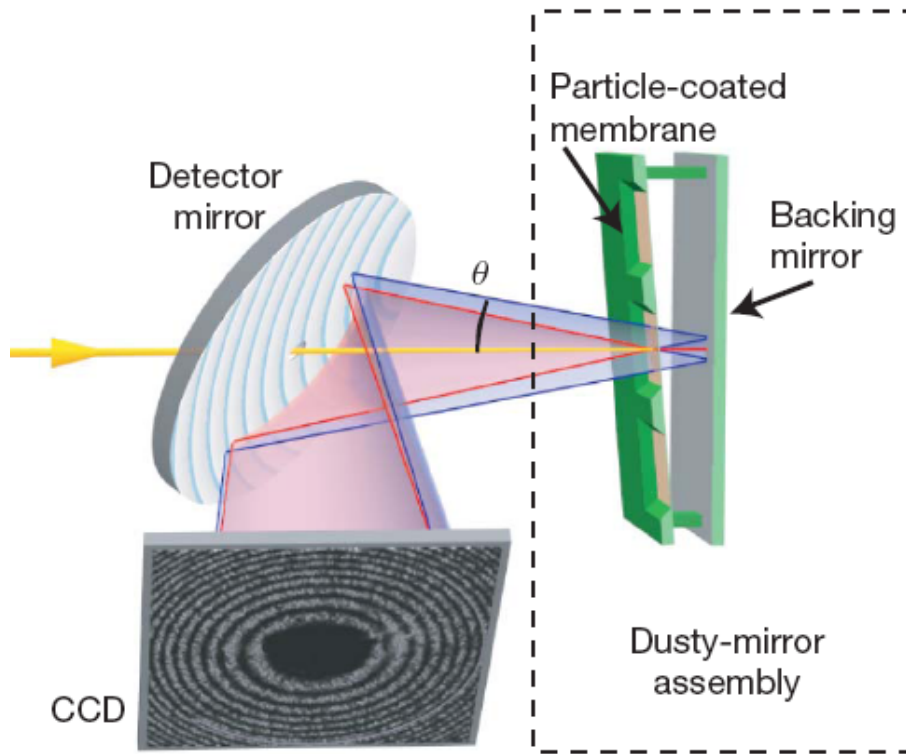

H. Chapman et al., Nature **448**, 676 (2007)

Expansion of 140 nm polystyrene balls

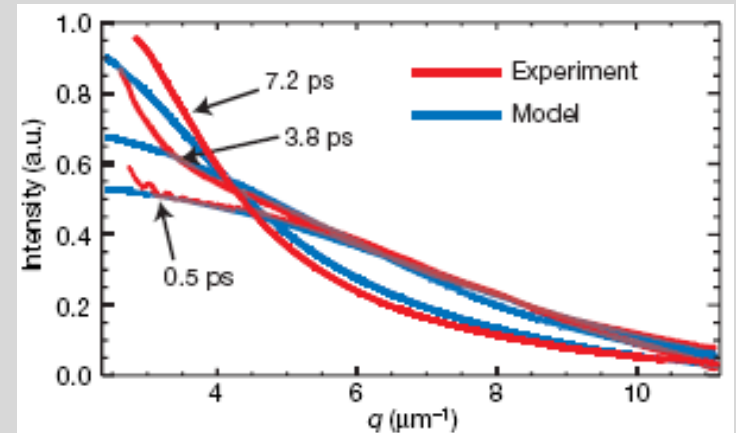
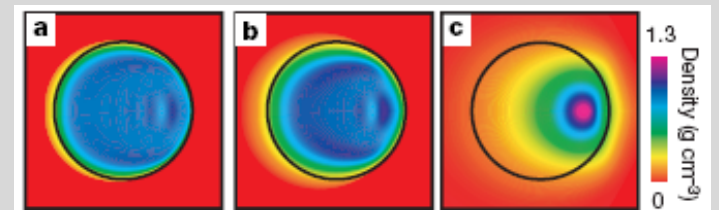

Broad scientific case

New opportunities

- ⇒ **ultrashort x-ray pulses:** ultrafast dynamics in variety of sam
- ⇒ **coherent x-ray pulses:** imaging of nano-particles & bio-mole
- ⇒ **extreme peak brilliance:** non-linear processes in atoms & pla

Scientific areas

- ⇒ **atomic, molecular, cluster physics:** gases, jets, traps, ...
- ⇒ **high energy density sciences:** plasmas at near-solid density
- ⇒ **condensed-matter physics:** surfaces, phase trans., magnetis
- ⇒ **materials science:** imaging, time-resolved processes, ...
- ⇒ **geo-sciences:** high-pressure states, ...
- ⇒ **chemistry:** solids, liquids, gases, ...
- ⇒ **life-sciences:** molecules, assemblies, cells, ...
- ⇒ **quantum optics:** non-linear, high-field, multi-photon, ...

LCLS, First Experiments (2000), www-ssrl.slac.stanford.edu/lcls
TESLA XFEL, Technical Design Report (2001), ---
BESSY FEL, Visions of Science (2001), www.bessy.de
ELETTRA, 2002, www.elettra.trieste.it/projects/fermi_public
European XFEL, 2006, www.xfel.eu
...

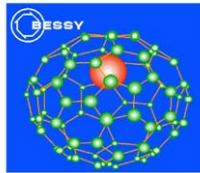

Visions of Science:
The BESSY SASE-FEL
in Berlin-Adlershof

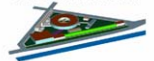

Outline

Results of current research

- soft x-ray FEL research
- hard x-ray preparatory work

Technology choices

- SASE process
- seeding schemes

Overview & status of facilities

- world-wide
- in Europe

Aspects of FELs for user operation

- general
- FLASH experience

Outlook/Summary

SR → FEL: Coherent emission

Spontaneous radiation

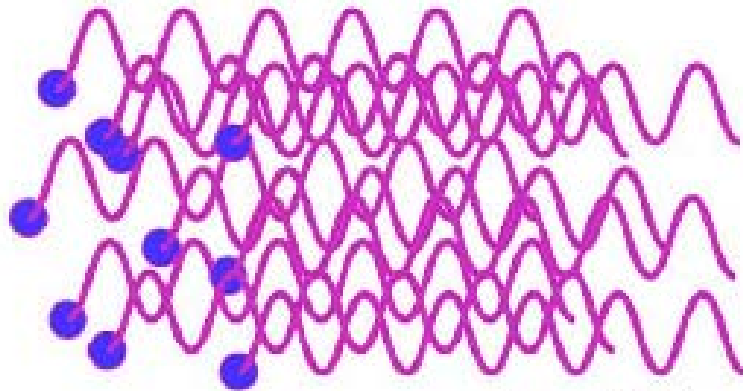

***N*-electrons
random distribution**

$$E_{spt} \sim \sqrt{N} E_1$$

$$P_{spt} \sim N P_1$$

Coherent radiation

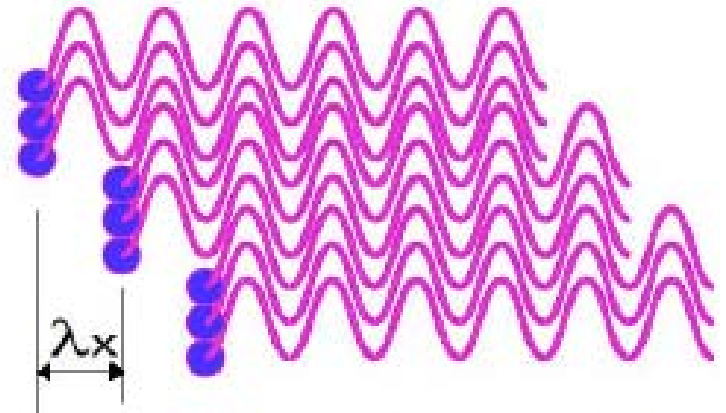

***N*-electrons
micro-bunched**

$$E_{coherent} \sim N E_1$$

$$P_{coherent} \sim N^2 P_1$$

Self-Amplified Spontaneous Emission SASE

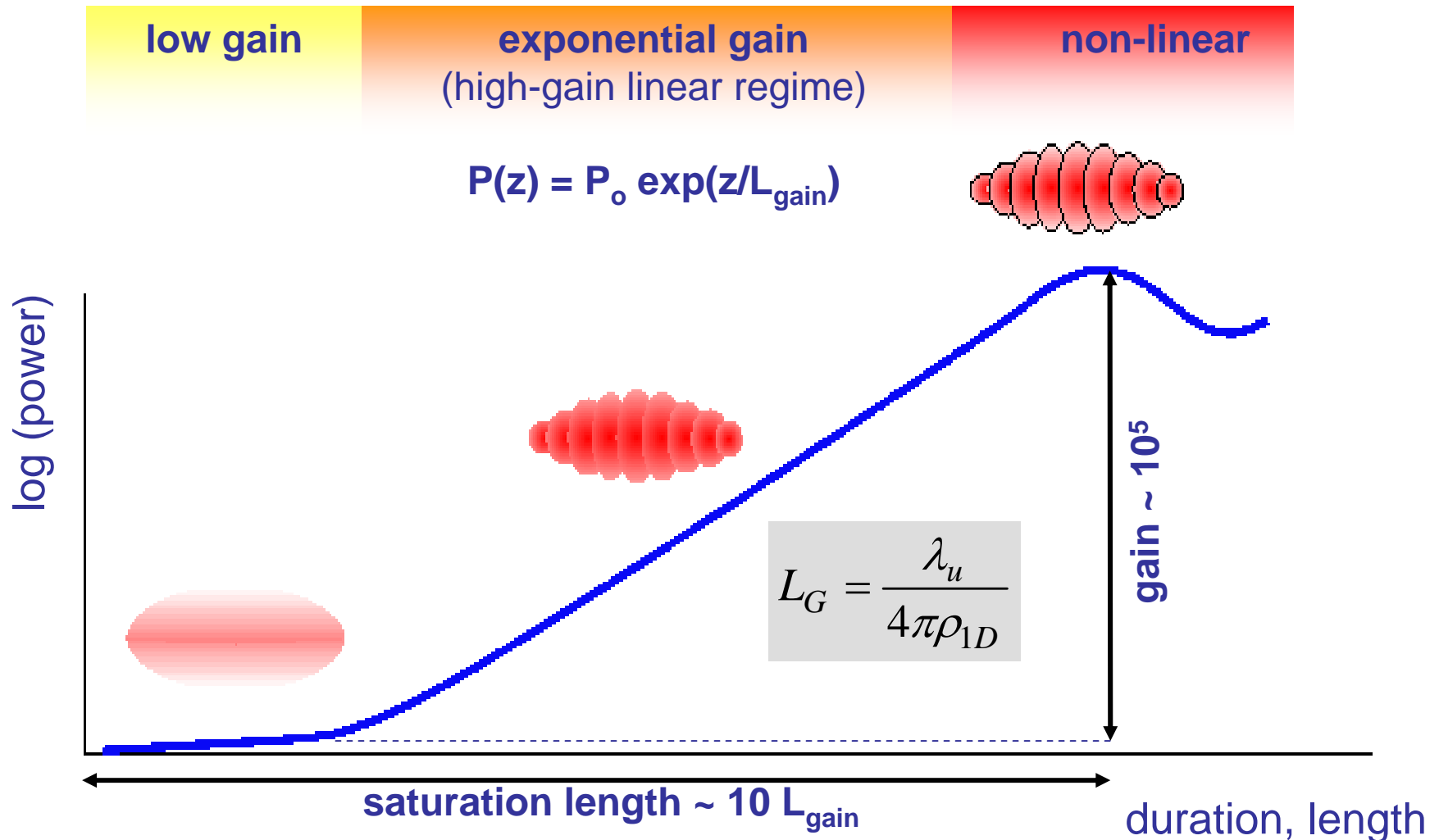

Some properties of FEL radiation

Peak brightness

$$\frac{\text{Number of photons}}{\Delta_x \Delta_{x'} \Delta_y \Delta_{y'} \times \text{bandwidth} \times \Delta_t}$$

- pulse intensities 10^{12} (X) – 10^{14} (sX)
- pulse duration 100 fs (X) – 10 fs (sX)
- bandwidth $<0.1\%$ (X) – $\sim 1\%$ (sX)

SASE FEL radiation exhibits **full** (high deg.) **transverse and limited longitudinal coherence**

- all electrons within single slices emit coherently
- limited number of longitudinal correlated slices

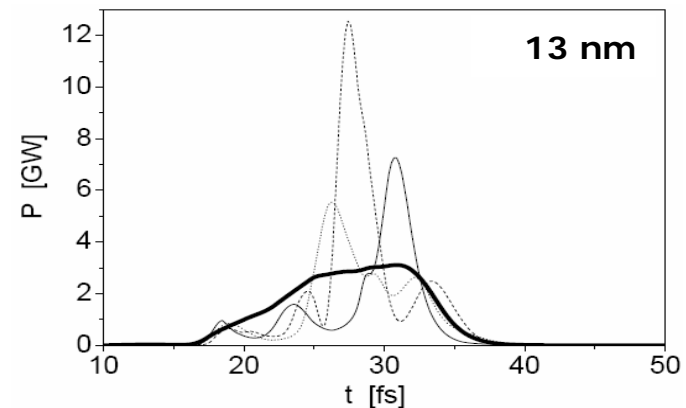
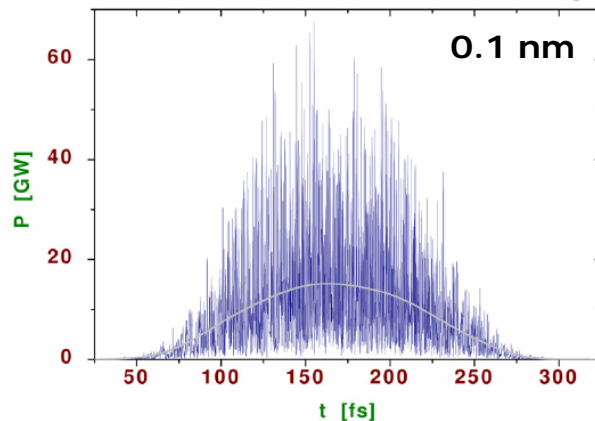

Seeded FEL radiation

Manipulate electron bunch using seeding pulse

- starting condition improved compared to noise (SASE case)
- improved radiation properties
- shorter gain length

Several concepts

- HGHG, self-seeding, e-SASE, as-pulses, HHG, ...
- in general easier for
 - ⇒ **lower energy electron beams**
 - ⇒ **longer wavelength FEL radiation**

Realisation

- First phase facilities do not foresee seeding
 - ⇒ **FLASH, LCLS, SCSS**
- Second phase facilities prepare for seeding
 - ⇒ **FERMI (HHG), SPARC-X (HHG), European XFEL (tbd), ...**

Repetition rate

Short-wavelength FELs operate in single pass mode

- Accelerator technology determines repetition rate
- Warm technology
 - ⇒ **RF power limit : 10 – 120 Hz**
 - ⇒ **RF pulse much shorter than ms**
 - pulse trains within these RF pulses are investigated
- Super-conducting technology
 - ⇒ **much higher RF power possible**
 - ⇒ **1. long RF pulse of order ms**
 - pulse trains of few 1000 pulses with MHz rep. rate possible
 - ⇒ **2. cw operation at reduced accelerating gradient**
 - Limit now is cooling power. Realistic: few 10 kHz @ 8-10 GeV

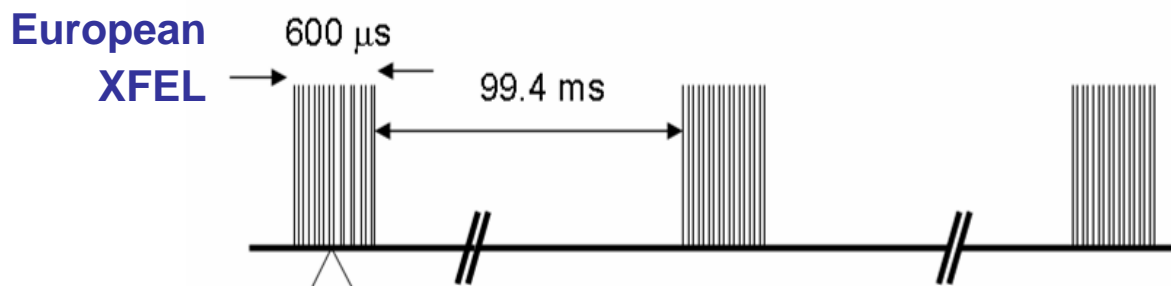

Outline

Results of current research

- soft x-ray FEL research
- hard x-ray preparatory work

Technology choices

- SASE process
- seeding schemes

Overview & status of facilities

- world-wide
- in Europe

Aspects of FELs for user operation

- general
- FLASH experience

Outlook/Summary

X-ray FELs worldwide

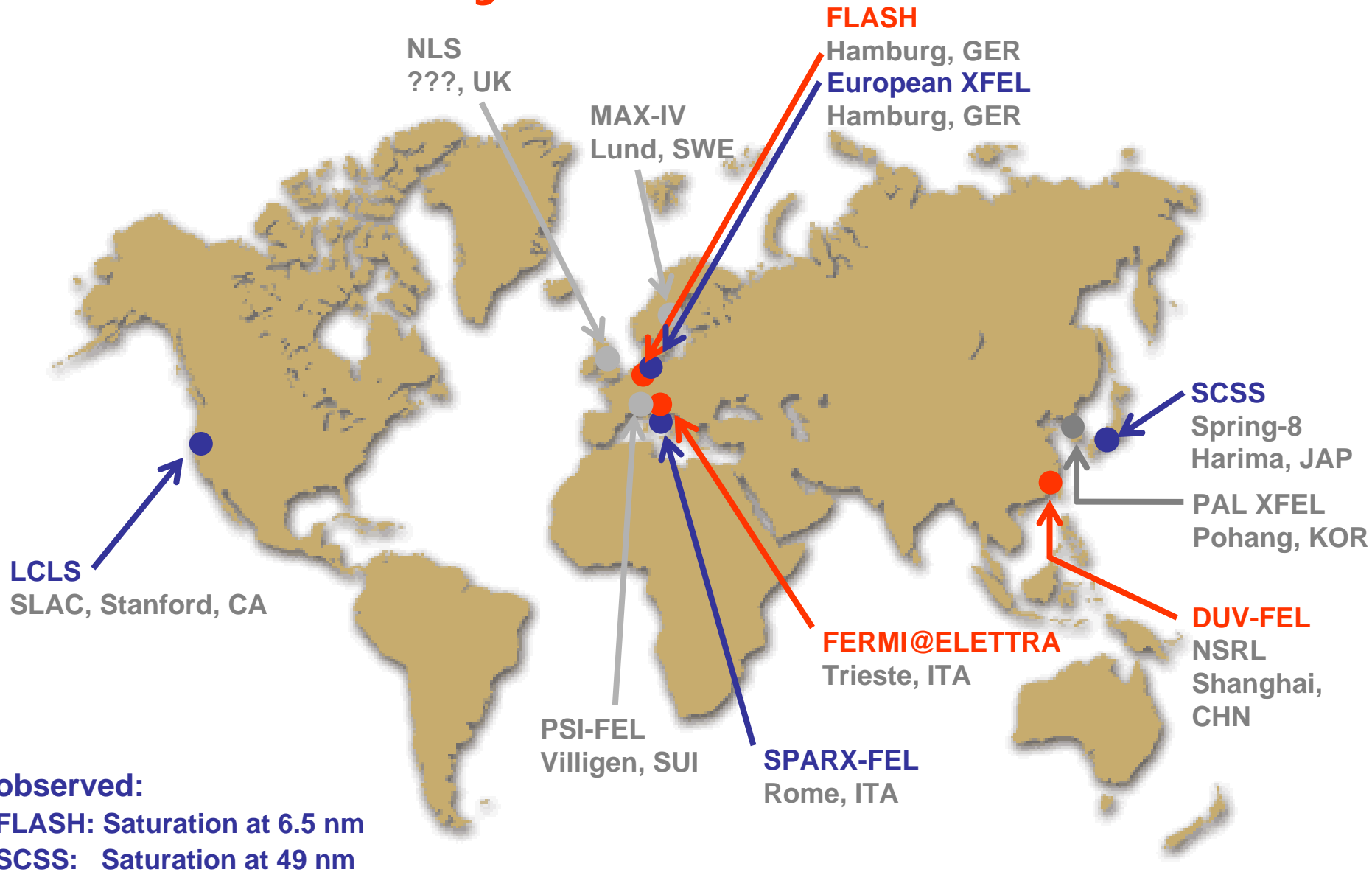

LCLS: about to start

First beam in summer 2009

- soft x-ray radiation (800 – 2000 eV)
- first call for proposals has passed: Sep 1, 2008
 - ⇒ **Atomic, Molecular and Optical phenomena instrument**

Hard x-ray FEL radiation summer 2010

- 5 – 8.5 keV (& 3rd harmonics radiation 24 keV)
- call for proposals in 2009
 - ⇒ **X-ray Pump Probe**

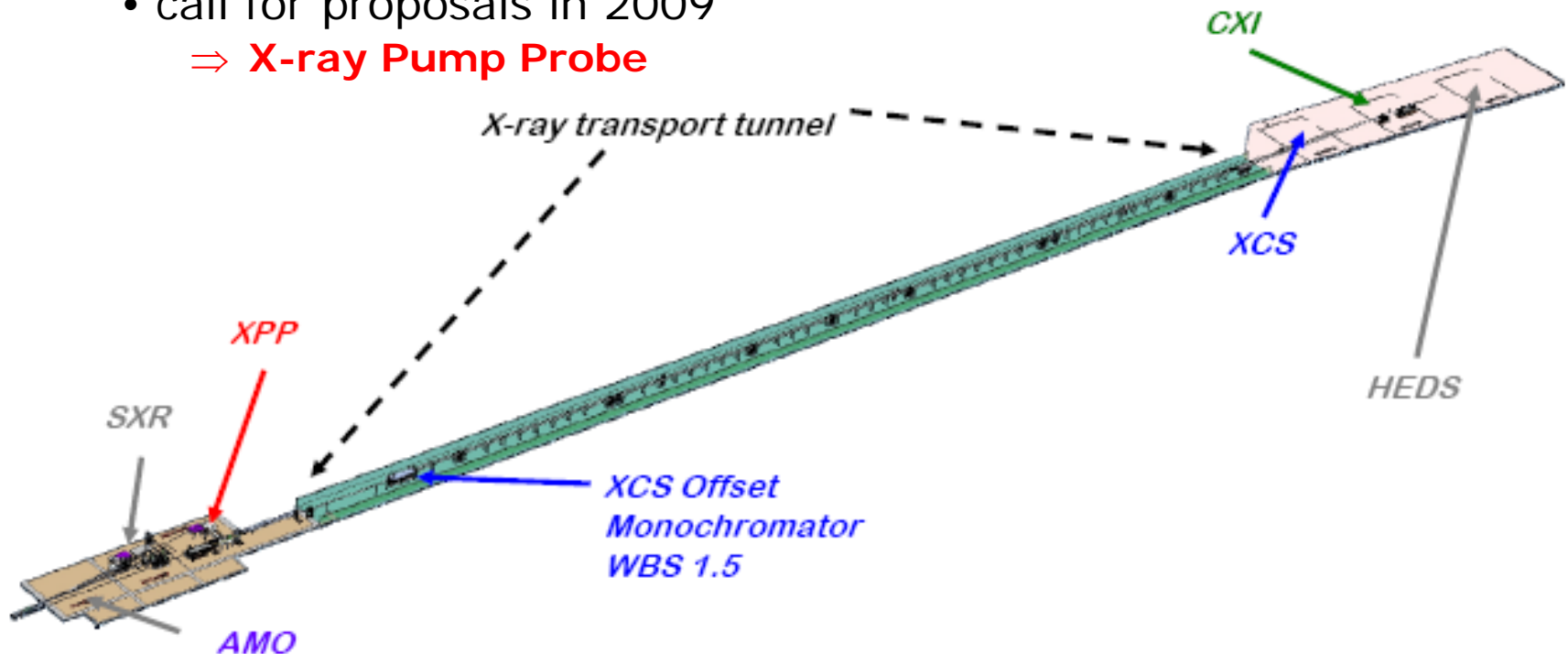

Spring-8 Compact SASE Source (SCSS)

Least known project

- different realisation of accelerator & undulators
 - ⇒ **thermionic DC electron gun**
 - ⇒ **buncher scheme**
 - ⇒ **in-vacuum undulators (2–3.5 mm gap, period 15 mm)**
- 12.4 keV with 6 GeV electrons

Parameters

- 1-3 SASE FEL undulators
- commissioning 2010
- operation 2011

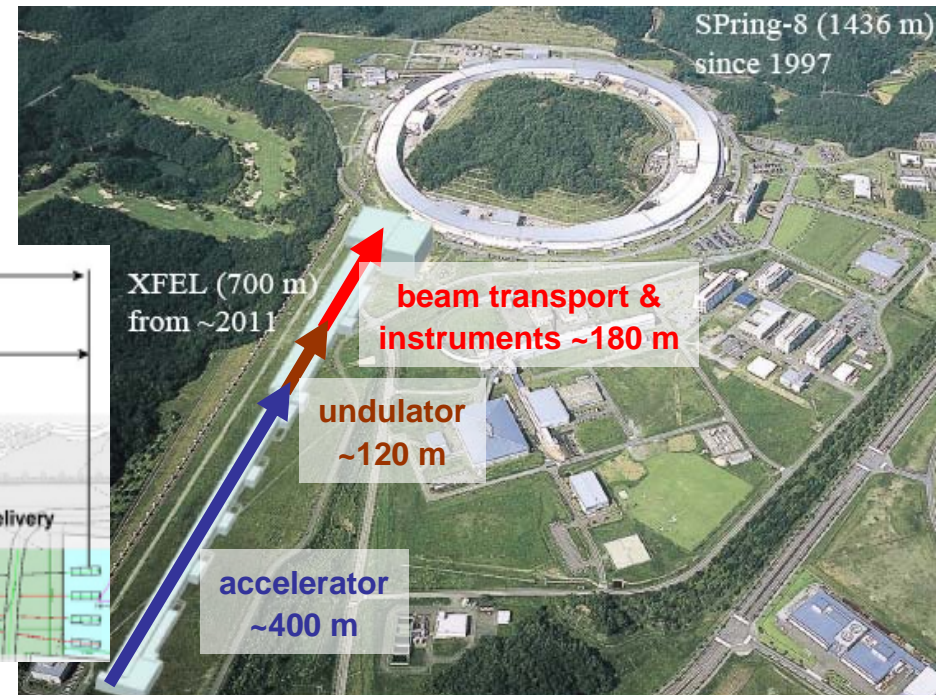
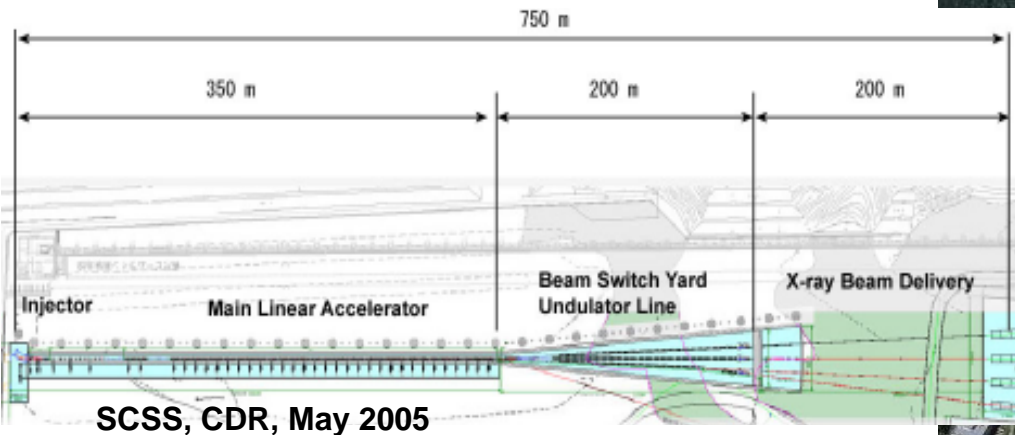

Soft & Hard X-ray FELs in Europe

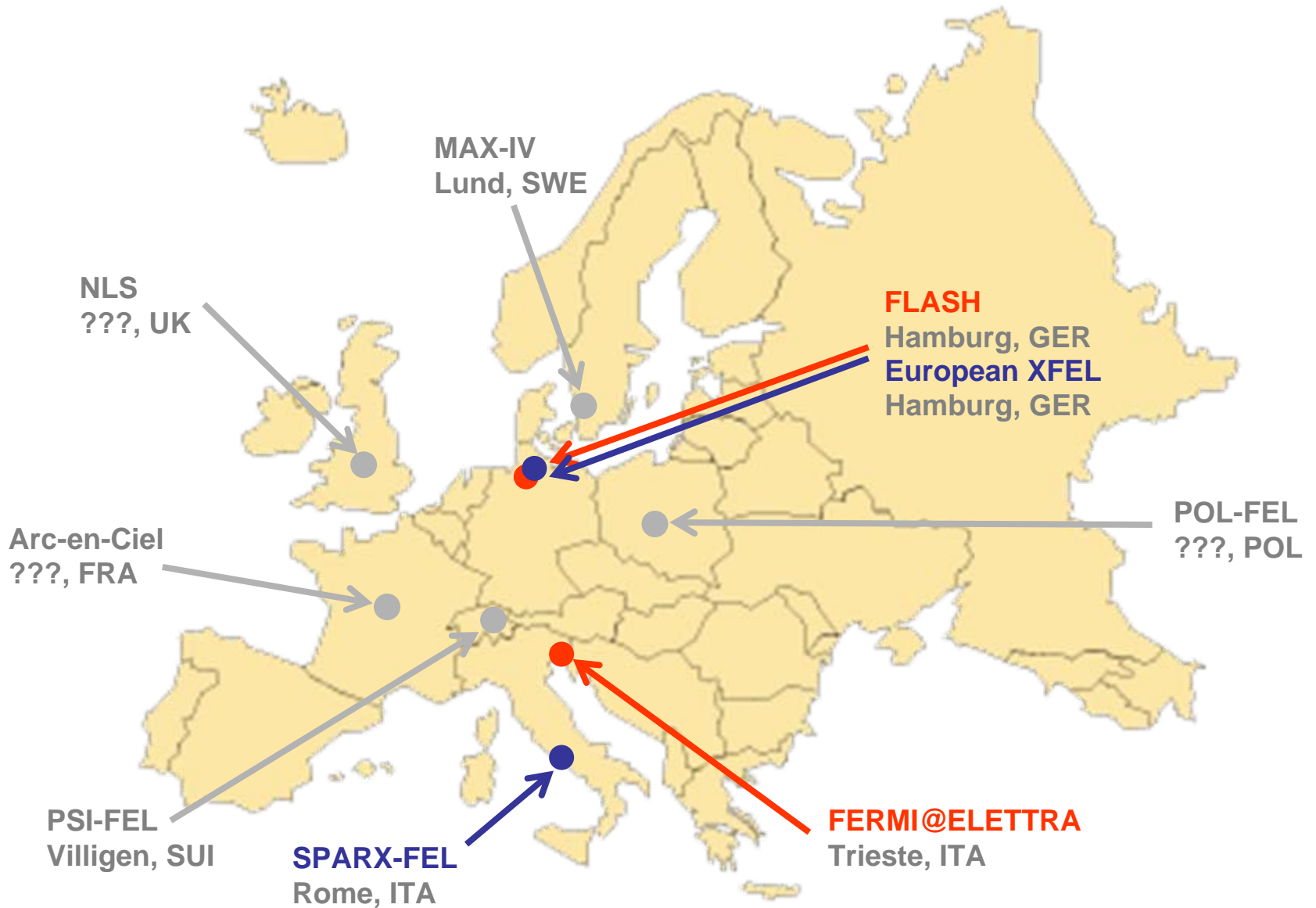

FLASH: the only user facility yet

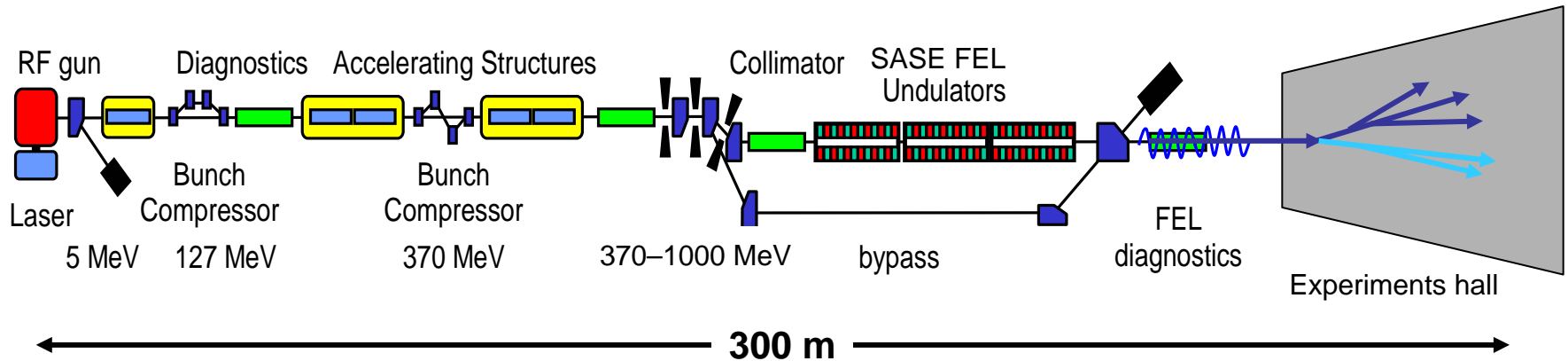

Electron & sX beam parameters

- emittance $\sim 2\pi$ mm mrad
- 1–2 kA peak electron current
- 10 Hz/1 MHz (8000 b/s)
- photon energy 20–200 eV
- pulse duration 10–50 fs
- bandwidth 0.5–1 %
- pulse energy 20–170 μ J
- odd harmonics: 3rd, 5th

W. Ackermann et al., *Nature Photonics* **1**, 336 (2007)

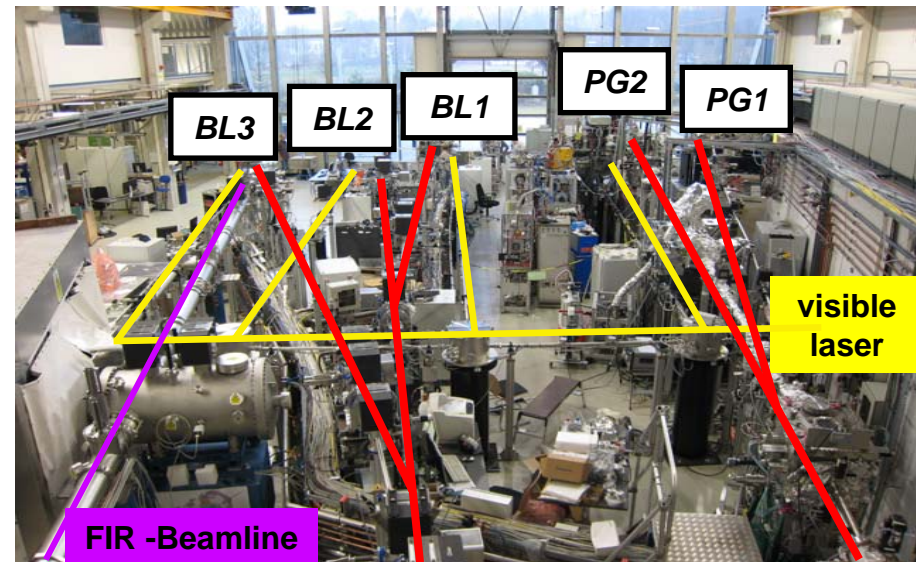

FLASH upgrades

seeding-FLASH

- 20 fs HHG pulses
- 30, later 13.5 nm
- 20 fs synch.
- power stabilization
- install & start 2009
- funded until 2010

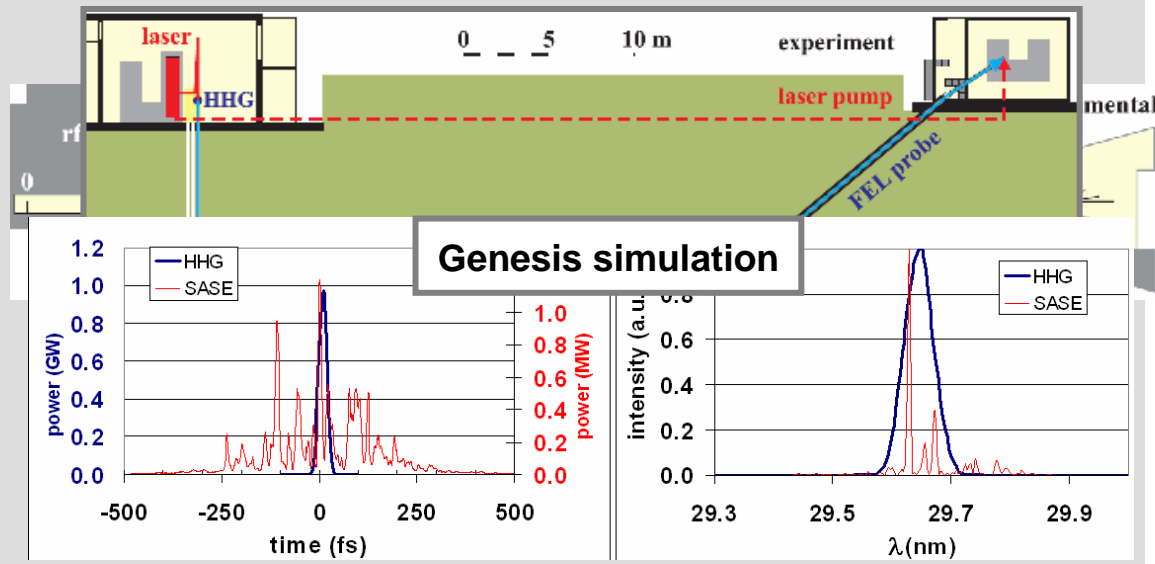

FLASH-II

- increase user beamtime
- variable gap undulator
- down to 4 nm
- HHG & HGHG seeding
- proposed for 2010-2013

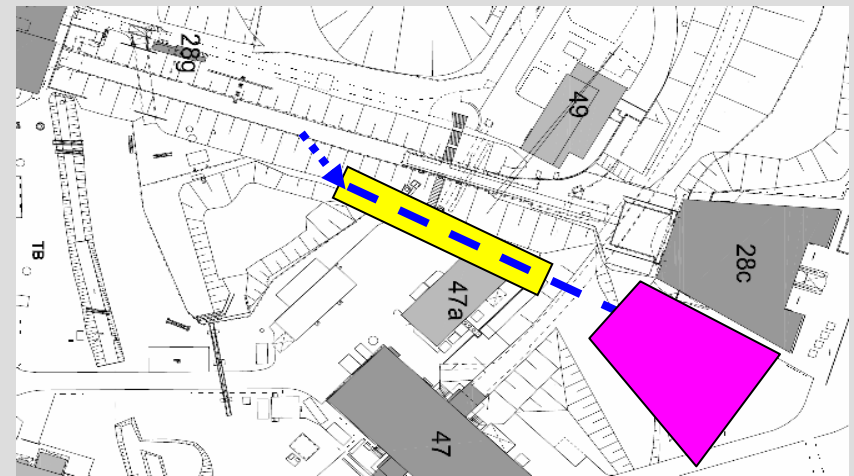

FEL projects under construction

FERMI@Elettra

- 50 Hz warm Linac
- 20–60 eV & 30–400 eV
- 50–200 fs pulse duration
- HGHG seeding
- variable polarization
- 2 FELs/3 instruments
- ⇒ **DIPROI**
- ⇒ **EIS (→ TIMER & TIMEX)**
- ⇒ **LDM**
- project schedule
 - ⇒ **first photons Aug 2008**
 - ⇒ **civil constr. Jan 2009**
 - ⇒ **first experiments 2010**
 - ⇒ **full operation Jan 2011**

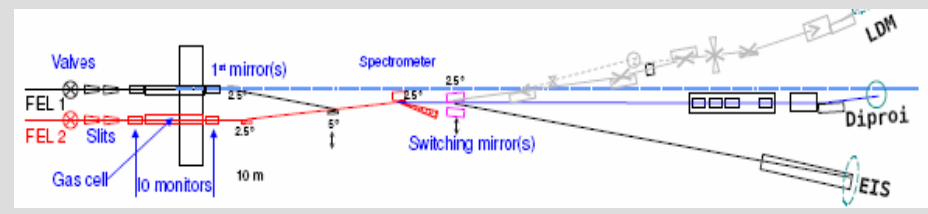
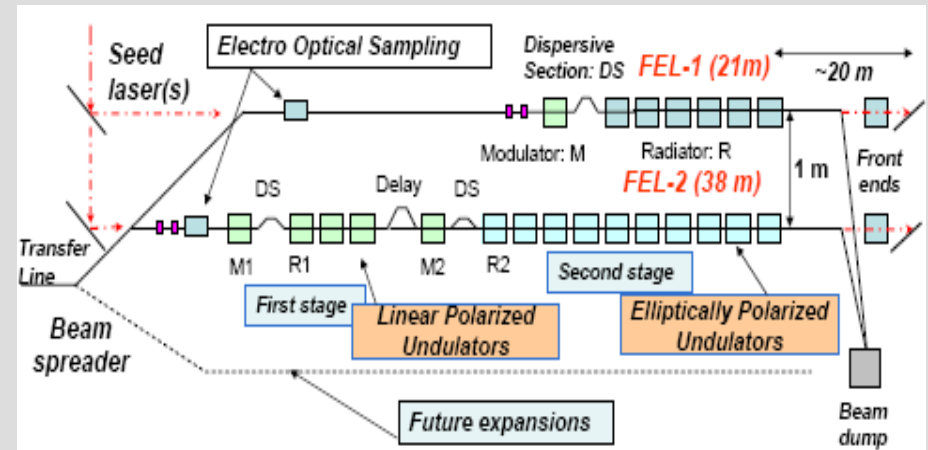
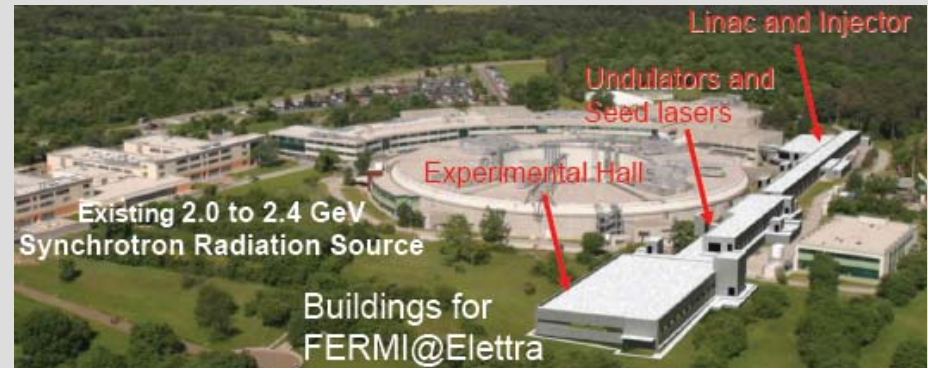

FEL projects under construction

SPARX-FEL

- 50–100 Hz warm Linac
- 40–300 eV (1.2 GeV)
- 300–2000 eV (2.4 GeV)
- 10–100 fs pulse duration
- SASE/HHG & HGHG seeding
- 3 FELs/up to 6 beamlines
- project schedule

- ⇒ R&D funds 2005
- ⇒ project funds 2007
- ⇒ first beam 2011
- ⇒ full operation Jan 2012

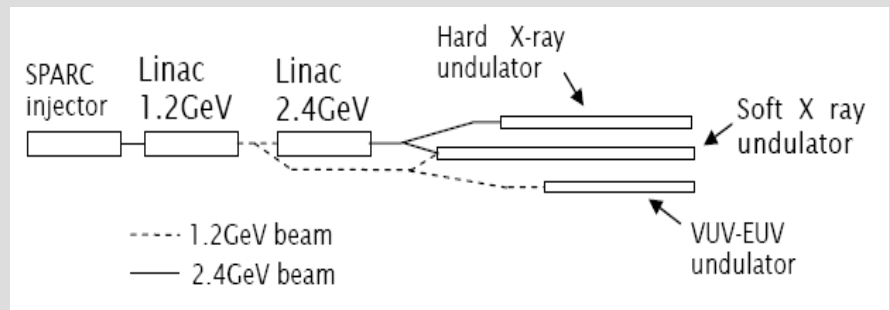

FEL projects under construction

European XFEL

- super-conducting accelerator
- 10 Hz/5 MHz (30.000 b/s)
- 0.5–12.4 keV (10/17.5 GeV)
- <100 fs pulse duration
- 5 beamlines/10 instruments
 - ⇒ **start version with 3 BLs and 6 instruments**
- var. extensions possible
 - ⇒ **seeding**
 - ⇒ **more instruments**
- project schedule
 - ⇒ **launch Jun 2007**
 - ⇒ **civil constr. Nov 2008**
 - ⇒ **first beam 2014**
 - ⇒ **operation end 2015**

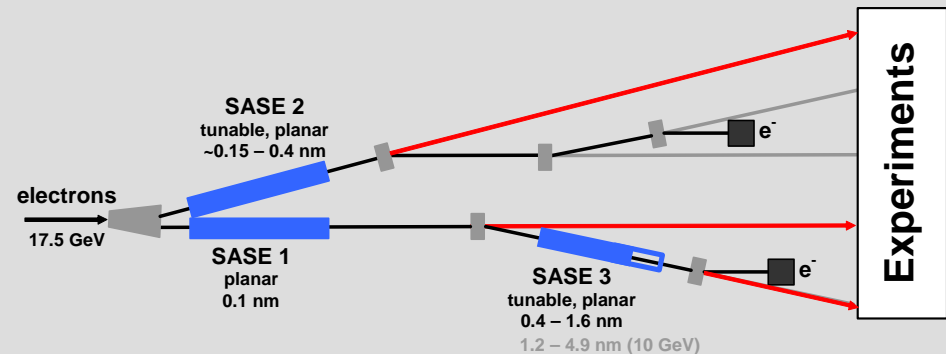
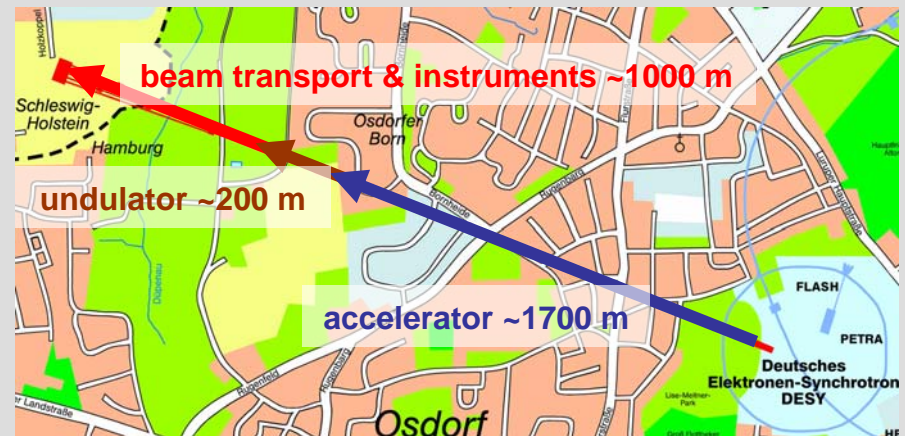

FEL projects under preparation

PSI-FEL

- 10–100 Hz warm, low emittance 6.4 GeV Linac
- <100 fs pulse duration
- SASE/HHG & HGHG sdg.
- project schedule

⇒ **decision Jan 2011**

⇒ **operation 2016**

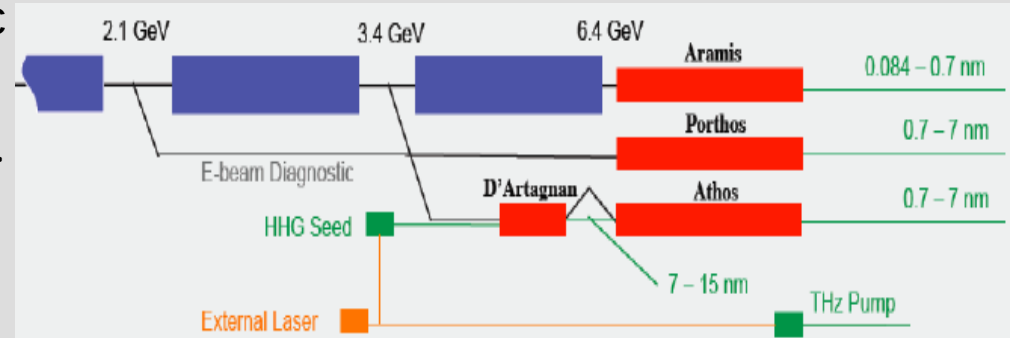

New Light Source

- 1 kHz (cw) Linac
- THz/IR–1000 eV
- ~20 fs pulse duration
- seeding
 - ⇒ **fs-synchronization**
 - ⇒ **transform limited pulses**
- project schedule ⇒ **proposal Oct 2009**



FEL projects under preparation

MAX-IV FEL

- 100 Hz warm 3.5 GeV Linac
- HHG & HGHG seeding
- project schedule
 - ⇒ **CDR 2008**
 - ⇒ **approval MAX IV 2009 (?)**
 - ⇒ **proposal/approval FEL ??**
 - ⇒ **first beam/operation FEL ??**

POL-FEL

- sorry, no detailed information

Arc-En-Ciel

- see presentation by M.-E. Couprie

Outline

Results of current research

- soft x-ray FEL research
- hard x-ray preparatory work

Technology choices

- SASE process
- seeding schemes

Overview & status of facilities

- world-wide
- in Europe

Aspects of FELs for user operation

- general
- FLASH experience

Outlook/Summary

General operation aspects

LINAC & FEL operation typically allows for operation of only a **single FEL-beamline-instrument** at a time

- switching e⁻-bunches usually at low repetition rate
- FEL operation increases energy spread of e⁻-bunch

Reliability/performance of LINAC is critical

- need for machine shifts: maintenance & performance

Performance of beam transport/x-ray optics is critical

- need for commissioning: maintenance & performance

Annual operation time of accelerator

- 6000 hrs per year at best (24/24 hrs, 250 days)
- ~4000 hrs for user operation per year might be possible
 - ⇒ **distribute to different operation modes (if available)**
 - ⇒ **distribute to different instruments (if available)**
 - ⇒ **distribute to scientific user teams at the instruments**
- assume 10 shifts of 12 hrs: ~30 user experiments/year

Parallel operation

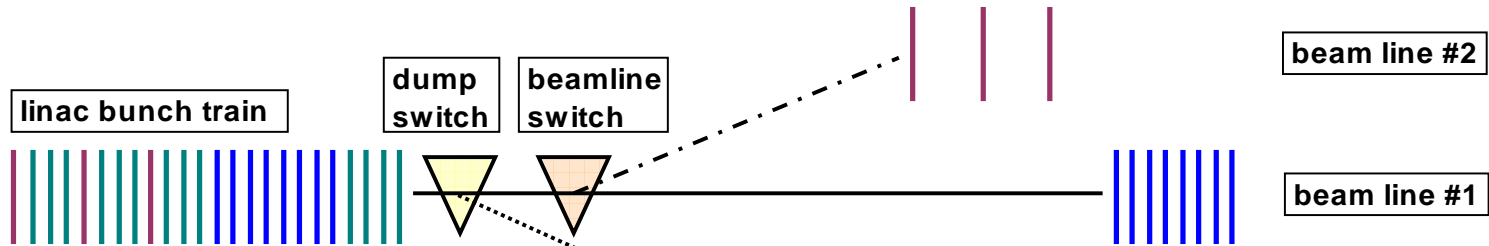

FLASH & European XFEL
→ fast distribution

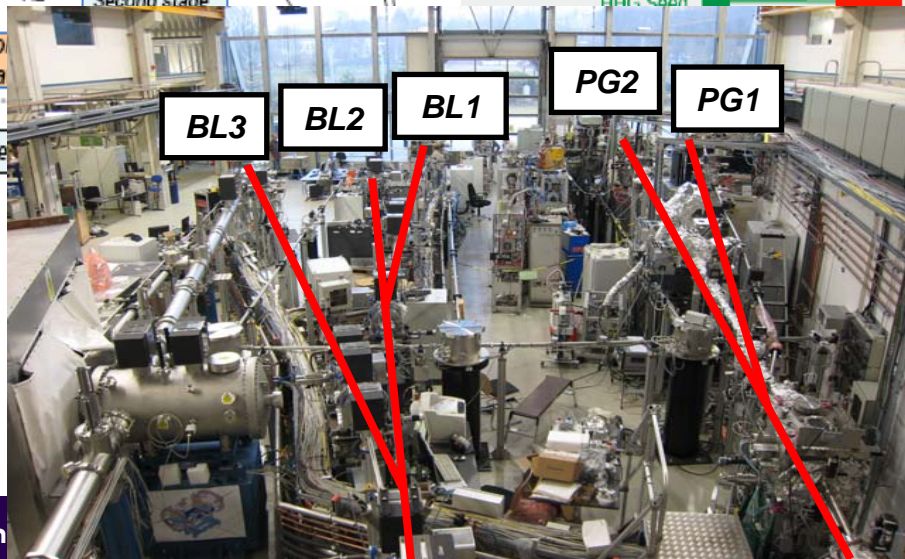
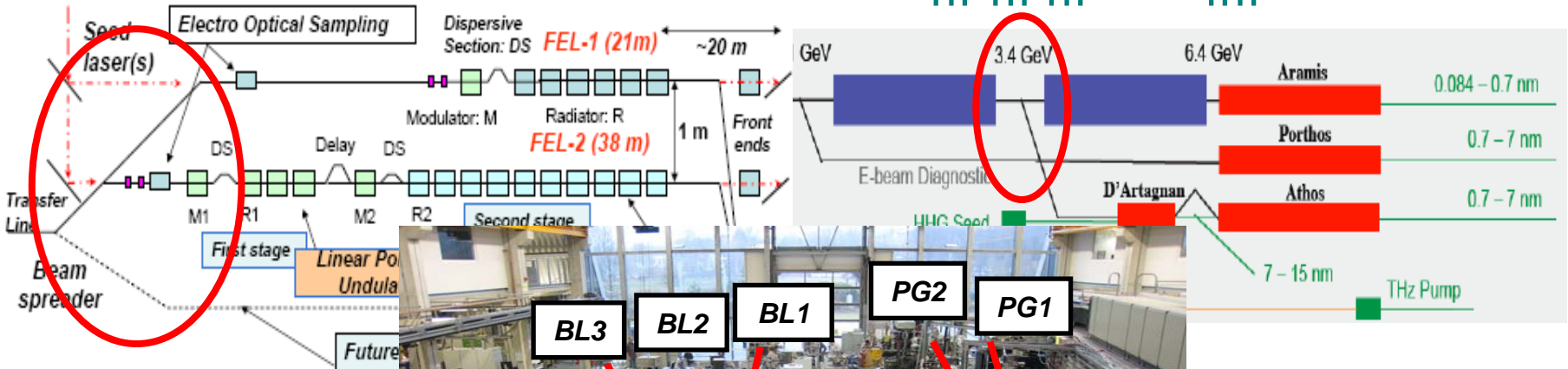

Principles of scientific access

User experiments

- peer review process for scientific proposals
- allocation of beamtime (# of shifts, period)
 - ⇒ **cross-check of parameter request (FEL, Laser, other instrumentation, ...)**
- scheduling of experiments
 - ⇒ **24/24 operation might be required !!!**
 - ⇒ **complex experiments require availability of experts**
- carry-out experiments
 - ⇒ **high expectation of success**
 - ⇒ **accelerator-, beam transport -, optical laser - and sample facility teams have to be present/available to minimize failures of sub-systems**
 - ⇒ **complexity of 'new' experiments: commissioning ?**
- reports/publications
- new submissions & growing user community

Experience from FLASH

1st round of proposals

- 18 projects
- 2 beamtime periods from Aug 2005 – Mar 2007
- ~ 30 publications

Areas of research

- Femtosecond time-resolved experiments
- Interaction of ultra-intense XUV pulses with matter
- Investigation of extremely dilute samples
- Investigation of surfaces and solids

2nd round of proposals

- scheduling periods from Nov 2007 to Mar 2009 (414 12-hr shifts)
- 45 proposals have requested 974 shifts
- 32 projects approved with 325 shifts

⇒ **enforce collaboration of research groups**

**Proposals for 3rd
round due 2009**

Scheduling at FLASH

Run 2: May 2006 to March 2007

- in-between shutdowns
- 45 weeks or 7728 h
- User experiments had 3840 h of beam time (47 %) with 2798 h of actual beam delivery (73%)

Total operation time: 7728 h

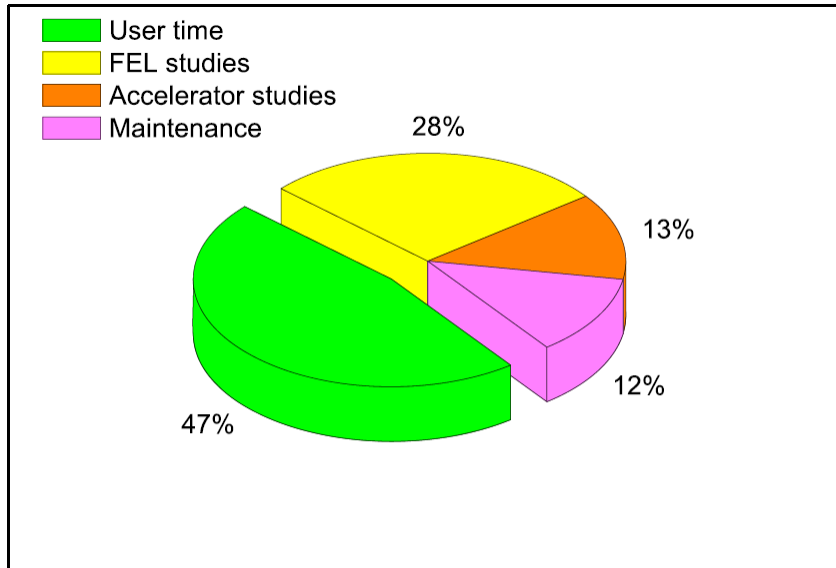

User beam time: 3840 h

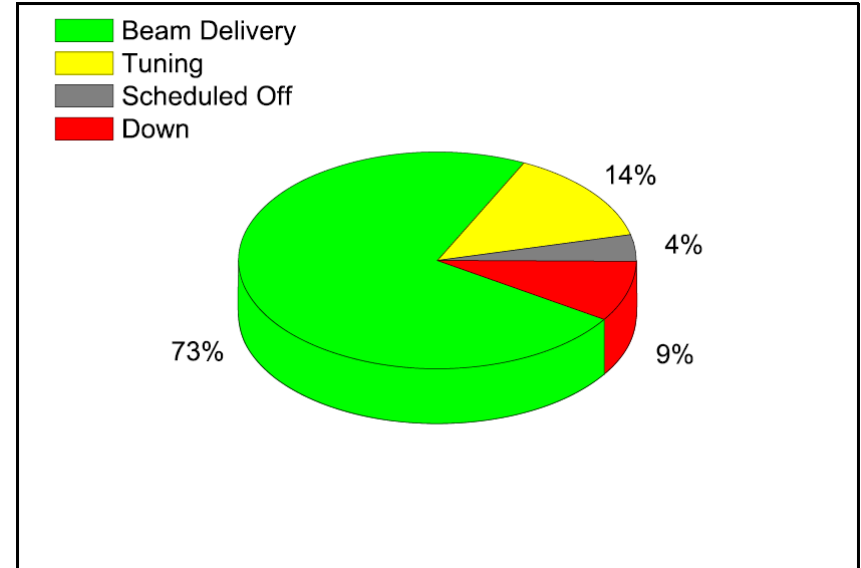

Next years user programs of facilities

FLASH

- start again spring 2010
- sharing accelerator operation

FLASH/time in hours	2010	2011	2012	2013
Maintenance				
Accelerator studies				
FEL studies				
User time				

Sorry, did not get the information. Should be of order 3000 hrs/yr

FERMI @Elettra

- 3 approved exp. programs (collaborations): **LDM, EIS, DIPROI**
- Initial Operational Year devoted entirely to these programs
- Beamtime allocation for following years is work in progress

LCLS

- planning uses 8760 hrs
- 5000 hrs for science program
- 75/25 % shares for general/IHR
- add. instrumentation → prioritized beamtime

LCLS	2009	2010	2011	2012	2013	2014
Maintenance	4,260	2,160	2,160	2,160	1,960	1,960
Machine studies electrons	2,750	1,300	1,300	1,300	900	900
Machine studies photons	1,250	1,300	1,300	1,300	900	900
Photon science experiments	500	4,000	4,000	4,000	5,000	5,000

European XFEL

- proposed are 4200 hrs for user operation

Summary

Short-wavelength FELs

- With FLASH the first user facility produces scientific results
Pulse duration -- Peak power -- Usage of coherent beams
Dynamics -- Imaging of nano-sized structures – High intensity effects
- With LCLS first hard x-ray machine is about to start
- Additional facilities are coming
FERMI@Elettra, SPARX, European XFEL, ..., PSI-FEL, NLS

Operational modes differ from storage rings

- New challenges in stability
- User operation asks for new challenges

Large flexibility is required to let new experiments succeed

Routine operation of FELs will still take some years

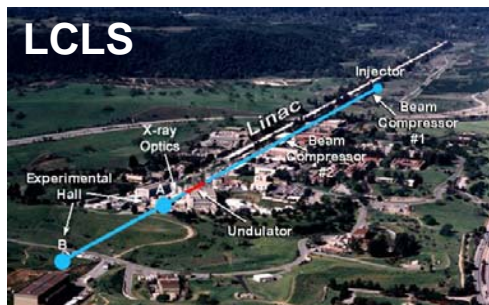
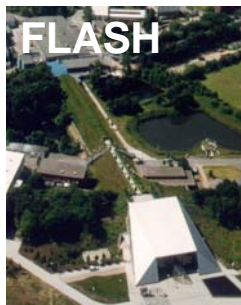

Acknowledgement

FLASH B. Faatz, J. Feldhaus, E. Plönjes
data: H. Pedersen, J. Crespo-Lopez,
H. Chapman/J. Hajdu

FERMI@Elettra S. Milton

SPARX-FEL L. Palumbo

PSI-FEL B. Patterson

LCLS J. Schneider

An architectural rendering of a modern, multi-story building with a white facade and large glass windows. The building features the 'XFEL' logo in large yellow letters on its side and roof. Two tall, vertical banners with the 'XFEL' logo stand in front of the building. A paved walkway leads to the entrance, where several people are walking. The scene is set against a blue sky with scattered white clouds and green trees in the background.

The end